

Joint Modelling of Longitudinal and Event Time Data

Robin.Henderson@lancaster.ac.uk

Peter Diggle
Angela Wood (née Dobson)

and

Per Kragh Andersen

Biomarkers

Prothrombin index in liver cirrhosis patients

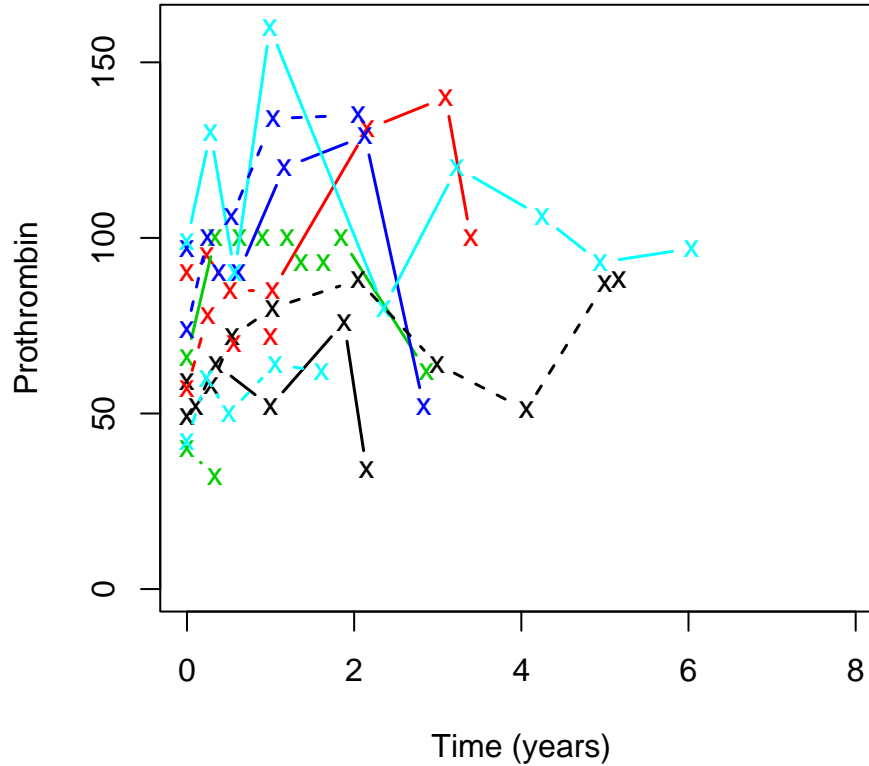

Biomarkers

Prothrombin index

Liver cirrhosis

CD4 counts

HIV/AIDS

Prostate specific antigen

Prostate cancer

Serum creatinine

End stage renal disease

⋮

Biomarkers

Prothrombin index

Liver cirrhosis

CD4 counts

HIV/AIDS

Prostate specific antigen

Prostate cancer

Serum creatinine

End stage renal disease

⋮

11.10.04 Google “biomarker” ⇒ 152,000 sites (0.69 seconds)

Biomarkers

Prothrombin index

Liver cirrhosis

CD4 counts

HIV/AIDS

Prostate specific antigen

Prostate cancer

Serum creatinine

End stage renal disease

⋮

11.10.04 Google “biomarker” ⇒ 152,000 sites (0.69 seconds)

11.10.04 Google “biometrics” ⇒ 918,000 sites (1.1 seconds)

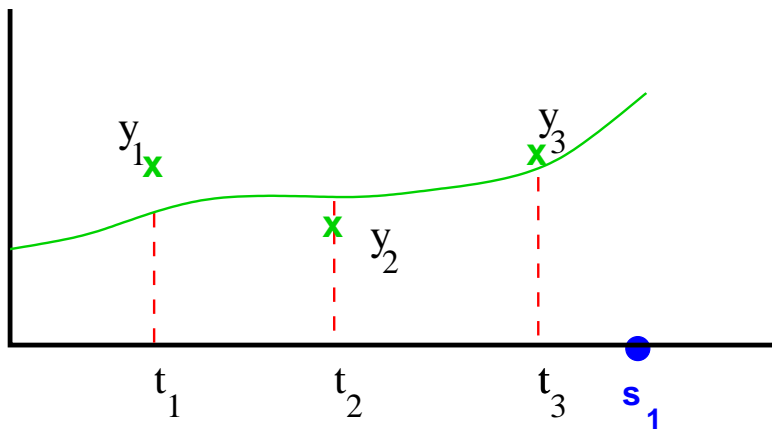
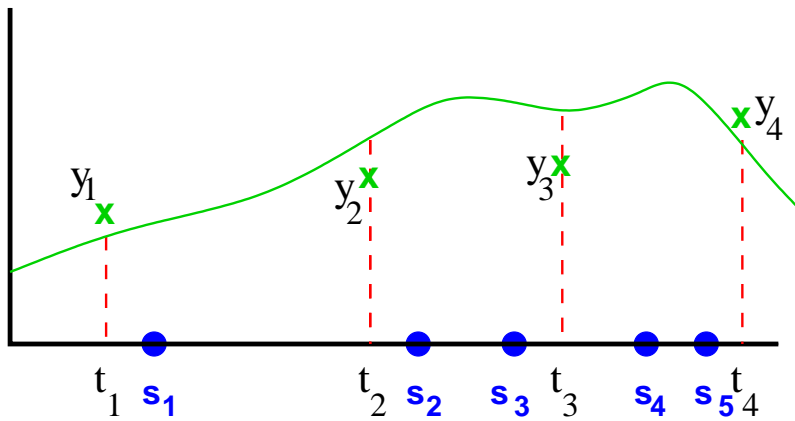

Methods

- LOCF, interpolation/extrapolation

Methods

- LOCF, interpolation/extrapolation
- Regression calibration

Methods

- LOCF, interpolation/extrapolation
- Regression calibration
- SIMEX

SIMEX

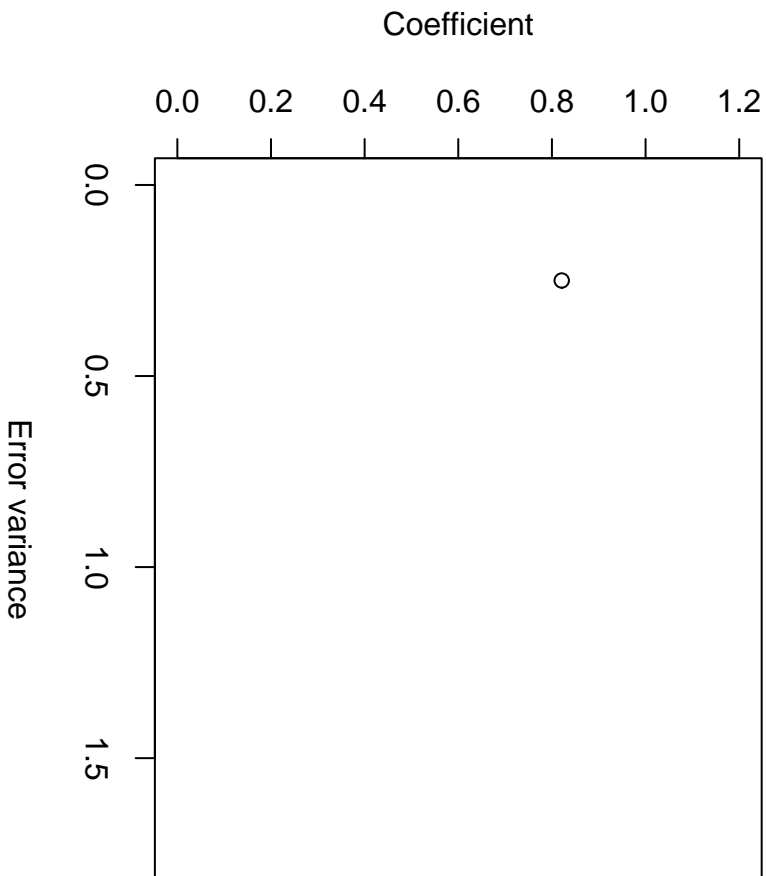

SIMEX

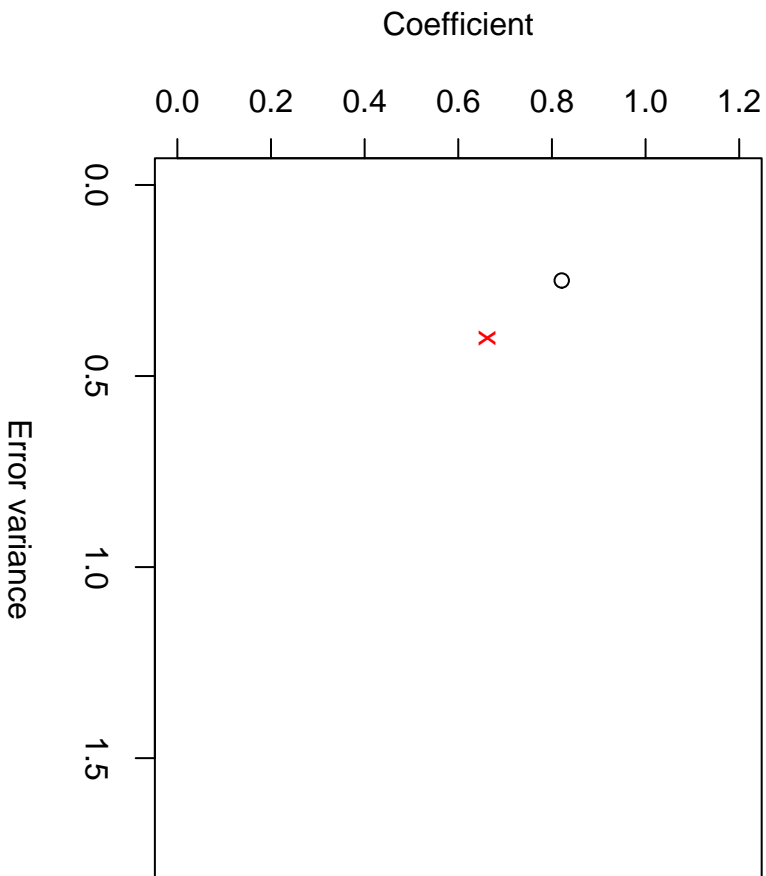

SIMEX

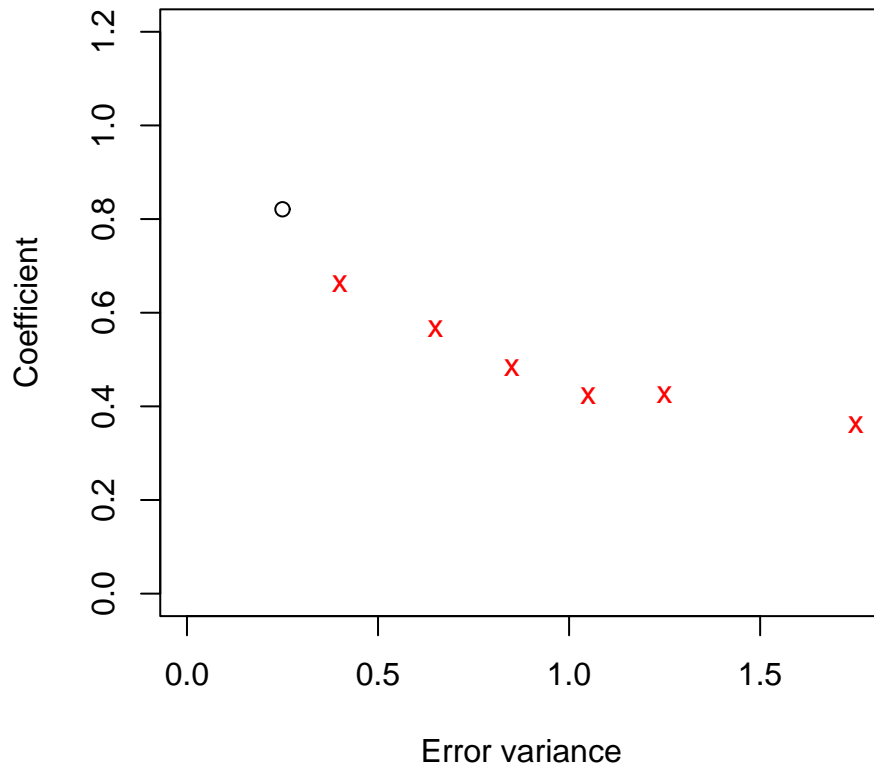

SIMEX

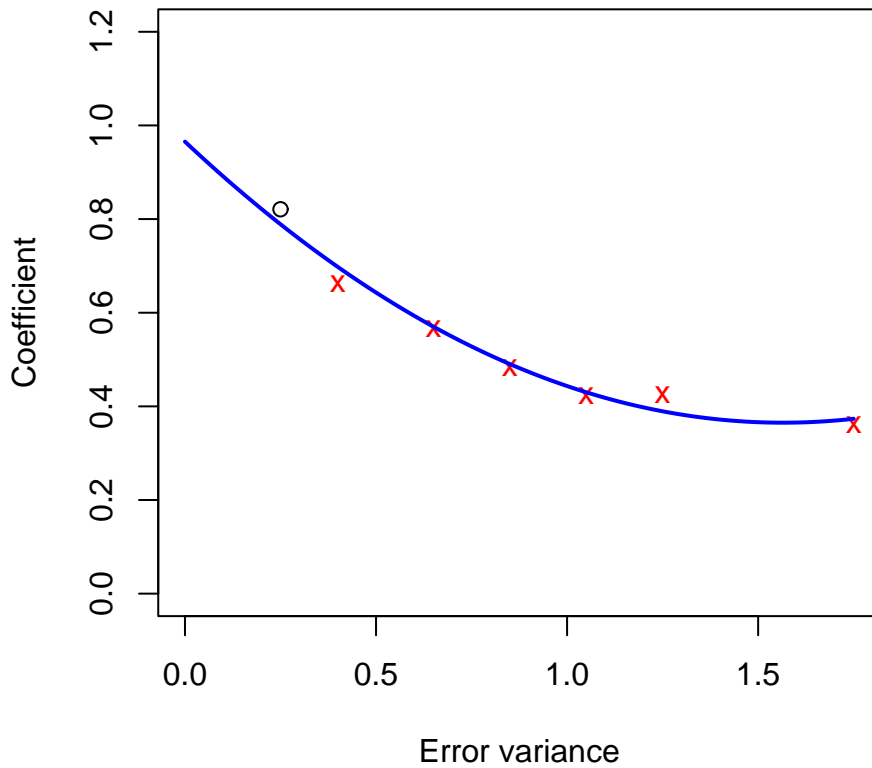

Methods

- LOCF, interpolation/extrapolation
- Regression calibration
- SIMEX
- Joint modelling - mid-1990's on, AIDS motivation

A longitudinal trial into treatment of schizophrenia

- Effect of treatment on PANSS (positive and negative symptom scale)
- Protocol: assessments at 0, 1, 2, 4, 6, 8 weeks
- 36% of patients dropped out for “inadequate response”
- 17% of patients dropped out for other reasons

Observed means

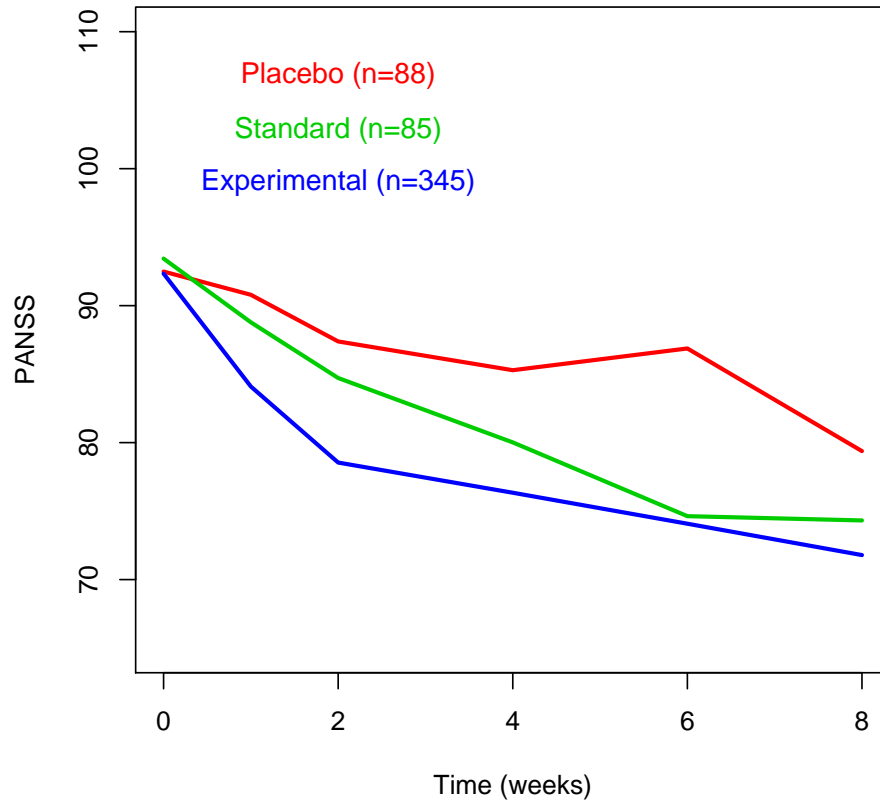

Biomarker

$$Y$$

$$\sim \mathbf{N}(\mathbf{X}\beta, \Sigma)$$

Biomarker

$$\mathbf{Y}$$

$$\sim \mathbf{N}(\mathbf{X}\beta, \Sigma)$$

Event process

$$\mathbf{N}$$

\sim proportional hazards

Y

N



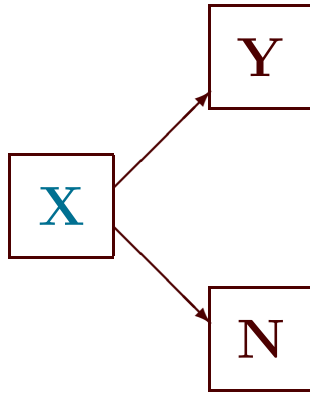

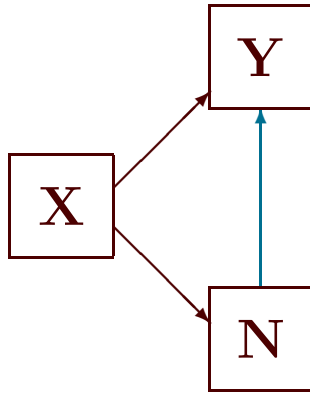

Pattern mixture (Little, 1993):

$$f(\mathbf{Y}, \mathbf{N} | \mathbf{X}) = f(\mathbf{Y} | \mathbf{N}, \mathbf{X}) \times f(\mathbf{N} | \mathbf{X})$$

Schizophrenia stayers through 3 visits

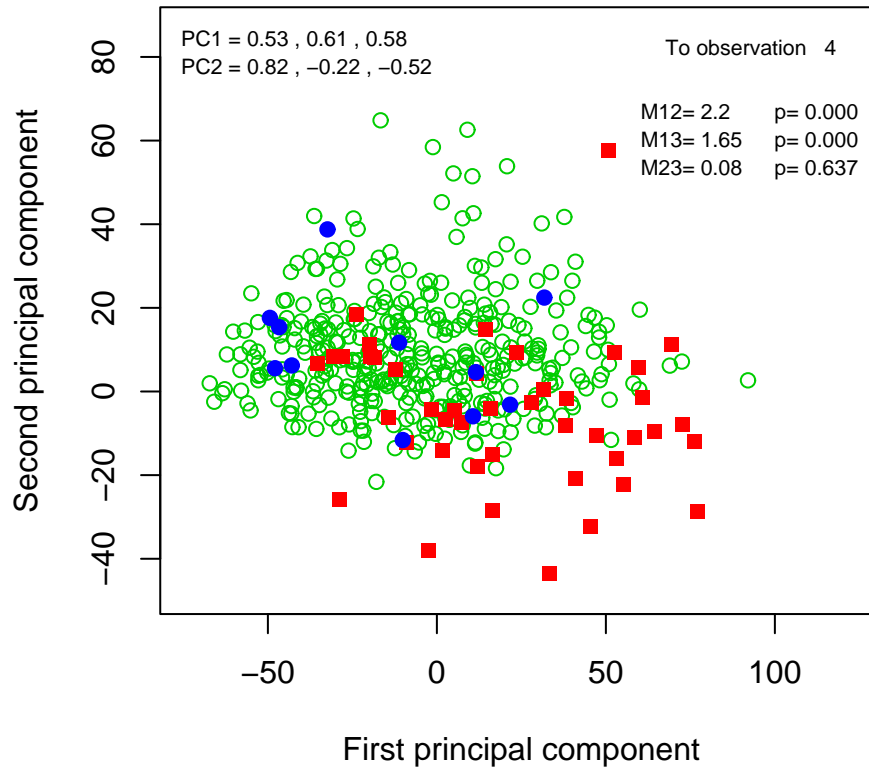

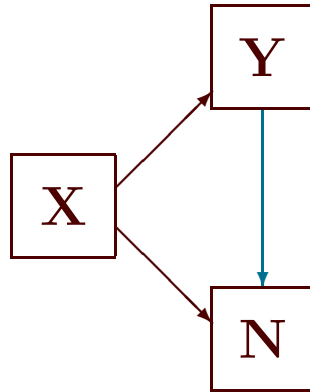

Selection (Heckman, 1976):

$$f(\mathbf{Y}, \mathbf{N} | \mathbf{X}) = f(\mathbf{N} | \mathbf{Y}, \mathbf{X}) \times f(\mathbf{Y} | \mathbf{X})$$

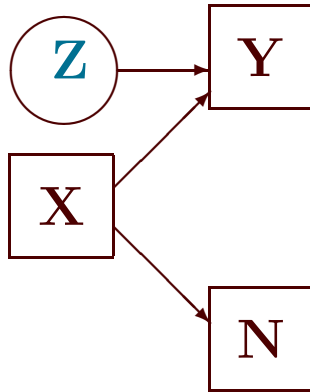

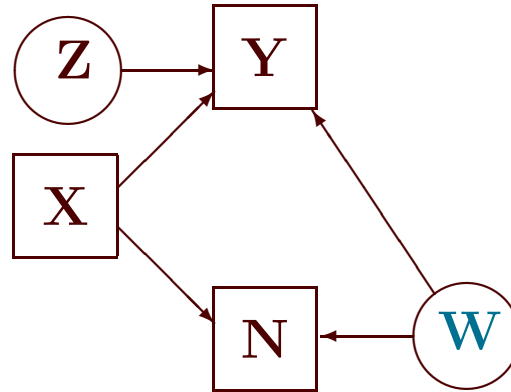

Random effects (Wulfsohn and Tsiatis, 1997):

$$f(\mathbf{Y}, \mathbf{N} | \mathbf{X}) = \int f(\mathbf{N} | \mathbf{W}, \mathbf{X}) \times f(\mathbf{Y} | \mathbf{W}, \mathbf{X}) \times f(\mathbf{W}) d\mathbf{W}$$

Illustrations

- Biomarker:

$$\mathbf{Y}(\mathbf{t}_i) = \mathbf{x}_1(\mathbf{t}_i)' \beta_1 + \mathbf{W}_1(\mathbf{t}_i) + \mathbf{Z}_i$$

$$\star \mathbf{W}_1(\mathbf{t}) = \mathbf{U}_1 + \mathbf{U}_2 \times \mathbf{t} \quad (\mathbf{U}_1, \mathbf{U}_2)' \sim \mathbf{N}(\mathbf{0}, \Sigma)$$

$$\star \mathbf{W}_1(\mathbf{t}) = \mathbf{U}_1 + \mathbf{V}(\mathbf{t}) \quad \mathbf{V}(\mathbf{t}) \sim \text{SGP}$$

⋮

- Hazard/intensity

$$\alpha(\mathbf{t}) = \alpha_0(\mathbf{t})\exp\{\mathbf{x}_2(\mathbf{t})'\beta_2 + \mathbf{W}_2(\mathbf{t})\},$$

- ★ $\mathbf{W}_2(\mathbf{t}) = \gamma\mathbf{W}_1(\mathbf{t})$

- ★ $\mathbf{W}_2(\mathbf{t}) = \gamma_1\mathbf{U}_1 + \gamma_2\mathbf{V}(\mathbf{t}) + \mathbf{U}_3$

- ⋮

Prothrombin index and survival

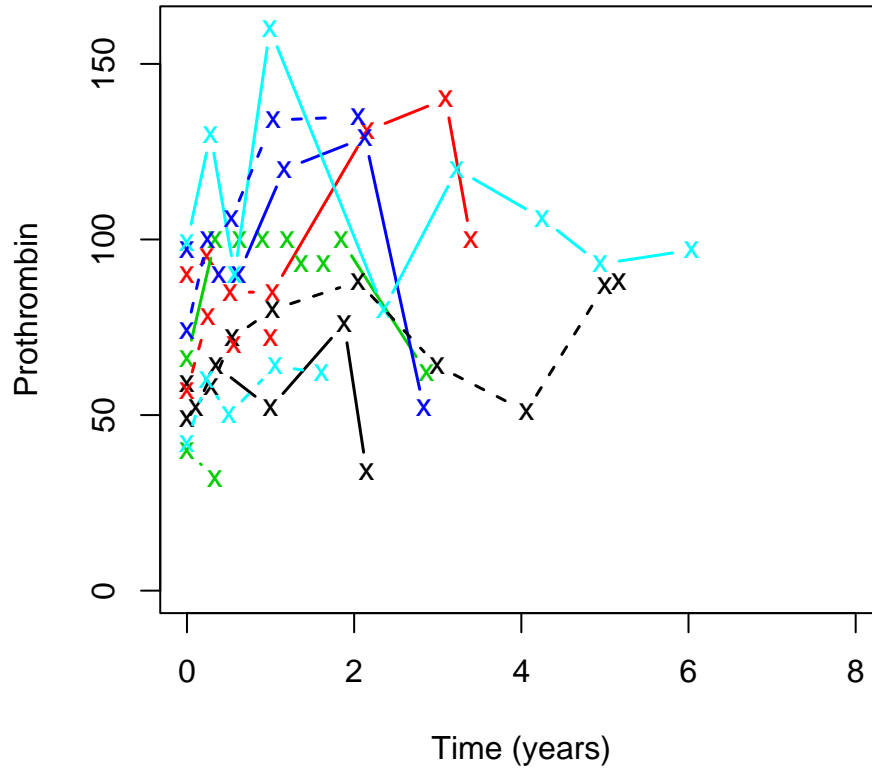

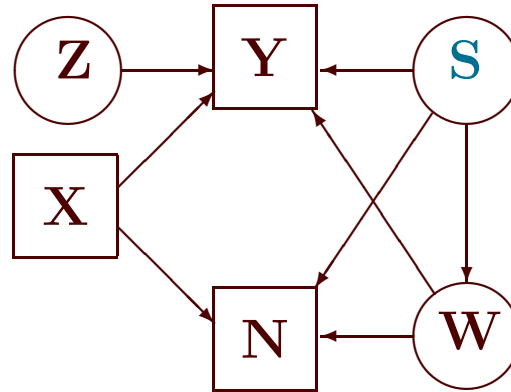

Crisis modelling:

Markov process $S \in \{\text{stable, crisis, dropout}\}$

Liver cirrhosis survival

- 31% 8-year survival rate
- $Y(t)$ = prothrombin index
- $W_1(t) = U_1 + V(t)$
- $W_2(t) = -0.025W_1(t)$
- Deviance against no association: 118 on 1df

Prediction: $\Pr(\text{survive 6 years}|\mathcal{F}_t)$

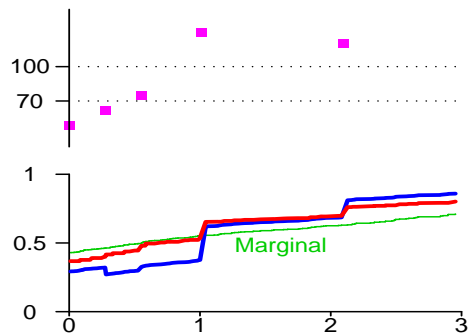

Time

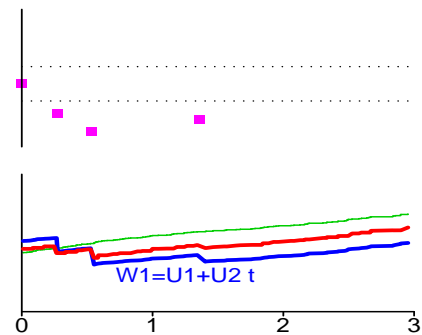

Time

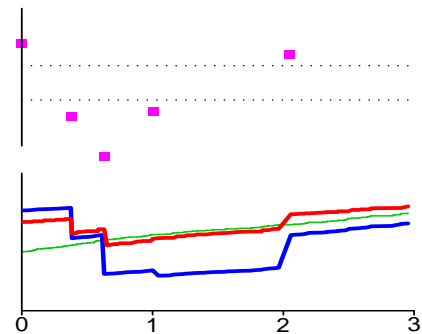
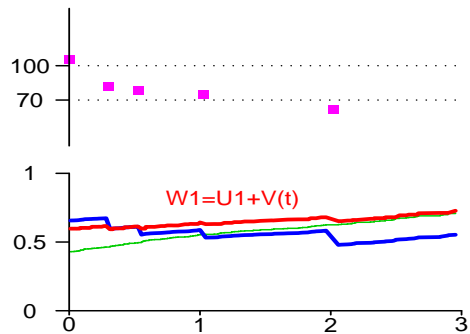

Explained variation in survival

	χ^2	df	V
VA lung	61	6	24%
VA prostate	120	11	14%
Multiple myeloma	17	5	14%
PBC	190	5	43%
Yorkshire lung	108	7	20%

Explained variation for liver data

$$W_1 = U_1 + V(t) \quad 12\%$$

$$W_1 = U_1 + U_2t \quad 12\%$$

PH, last Y carried forward 11%

Schizophrenia data

- $Y = \text{PANSS}$ (positive and negative symptom scale)
- $W_1(t) = U_1 + U_2 t$
- $W_2(t) = 0.349U_2 + 0.042W_1(t)$
- Deviance against no association: 222 on 2df

Observed means

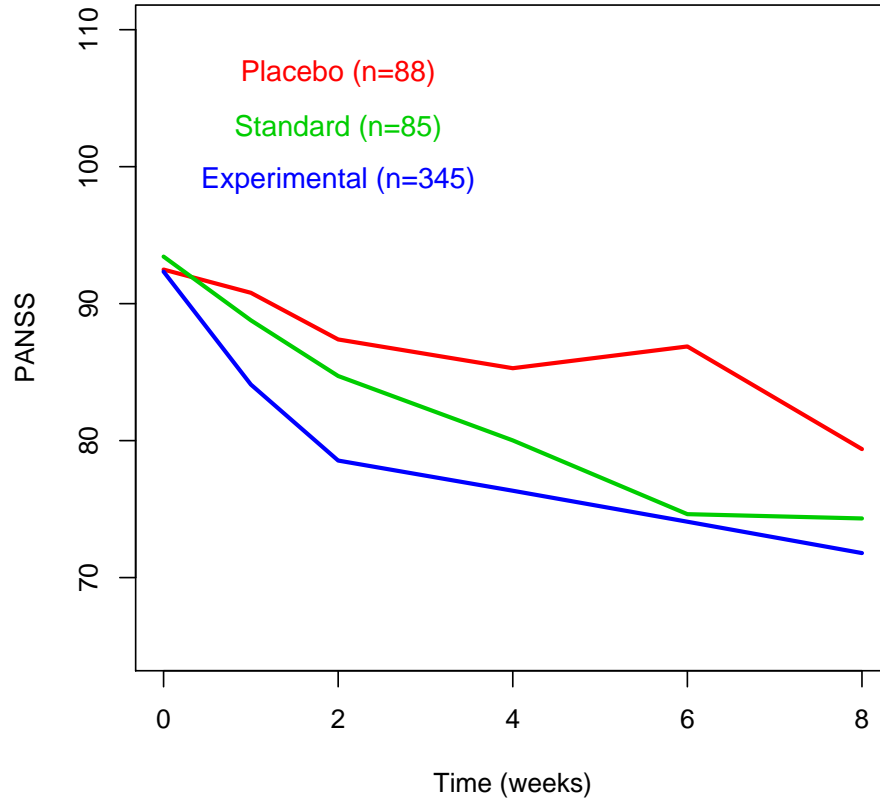

Estimated dropout-free profiles

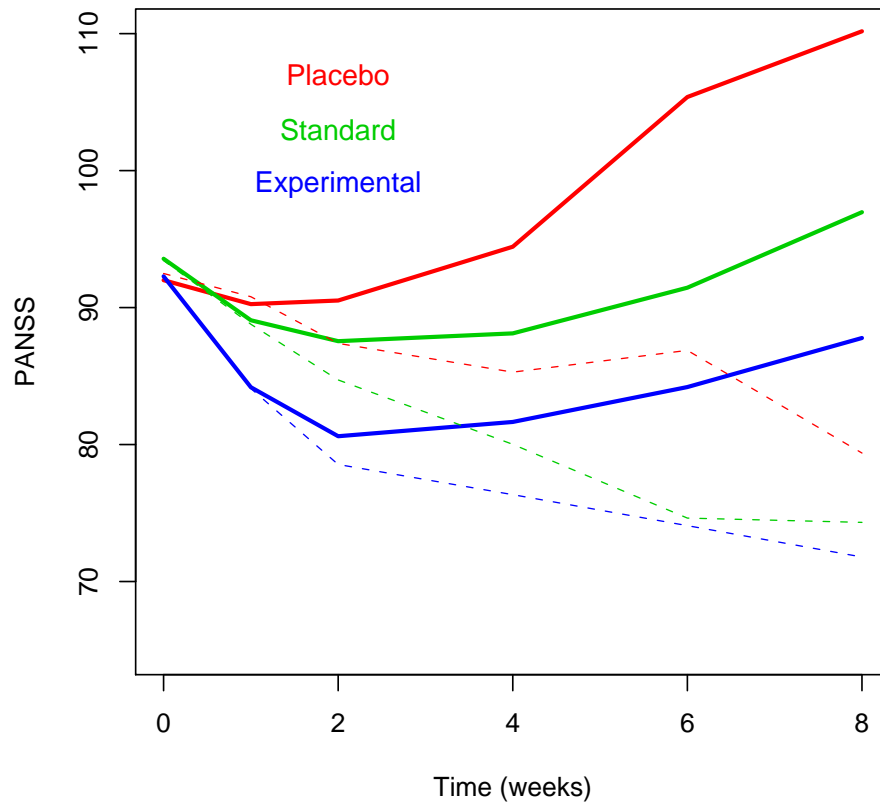

Other models

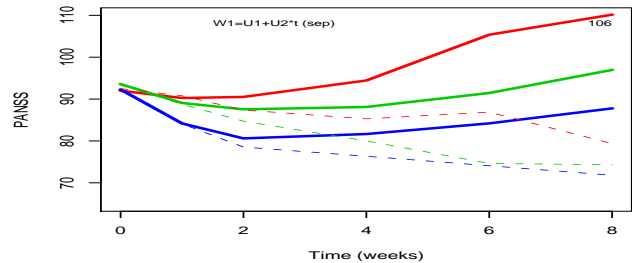
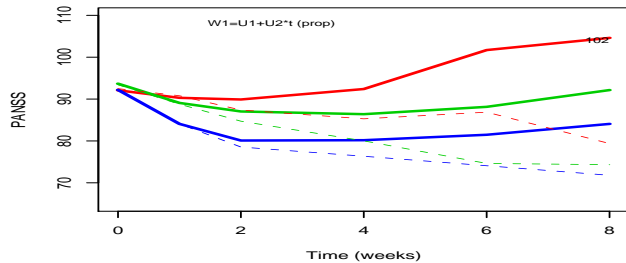
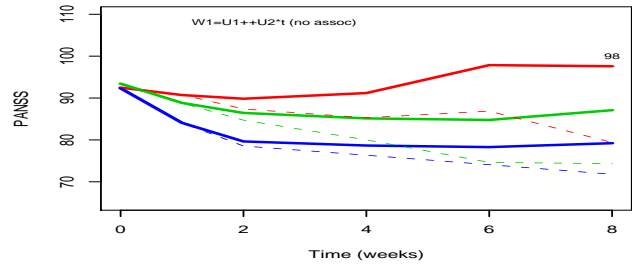
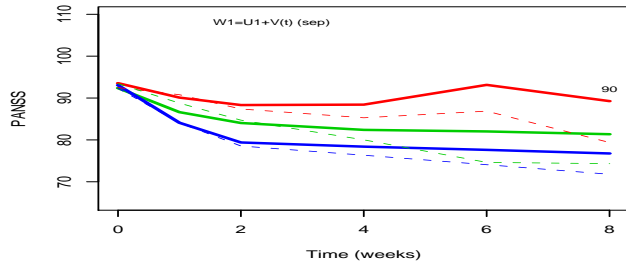
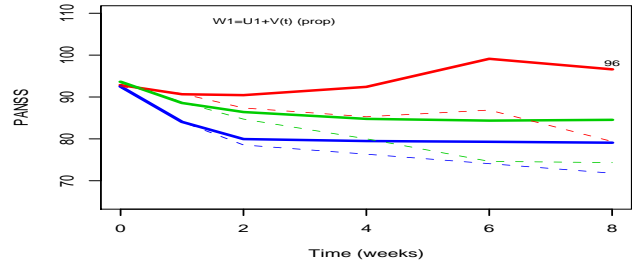
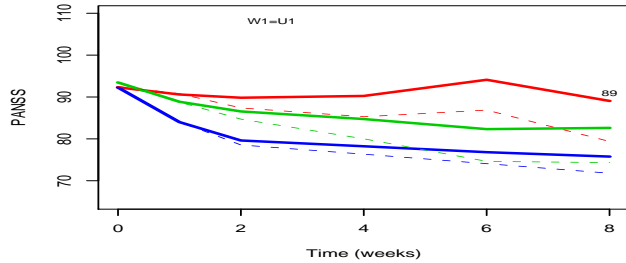

A leap of faith

- It is not possible to say what *might* have happened without dropout unless we make *untestable* assumptions (eg Rotnitzky et al, 2001)
- Sensitivity analyses recommended.

- Schizophrenia effect $E[Y(0) - Y(8)]$
- $W_1(t) = U_1 + U_2t$ $W_2(t) = \gamma W_1(t)$

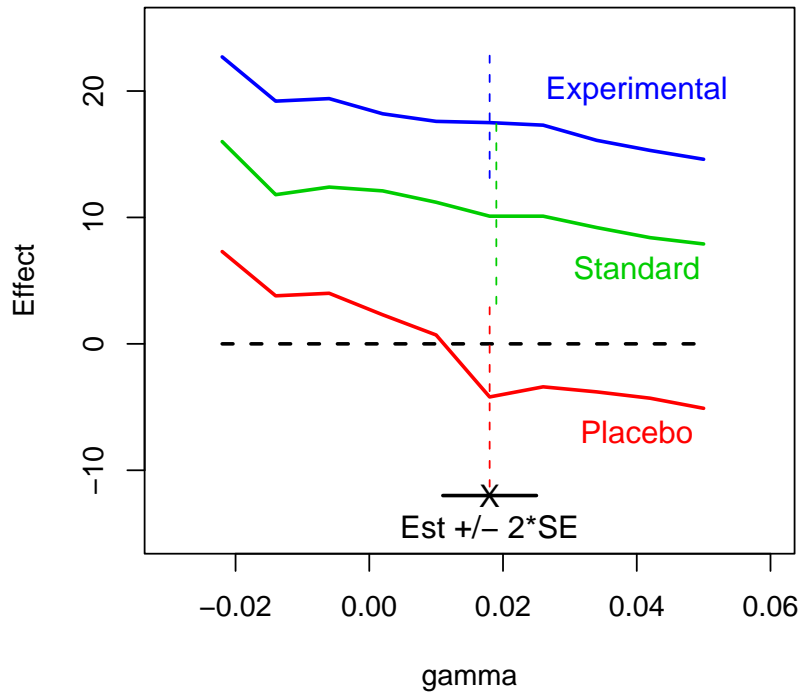

Residual analysis

Residuals $\mathbf{R}(\mathbf{t}) = \{\mathbf{Y}(\mathbf{t}) - \beta_1 \mathbf{x}_1(\mathbf{t})\}$

$$\mathbf{E}[\mathbf{R}(\mathbf{t})|\mathbf{N}] = \dots \quad \mathbf{Var}(\mathbf{R}(\mathbf{t})|\mathbf{N}) = \dots$$

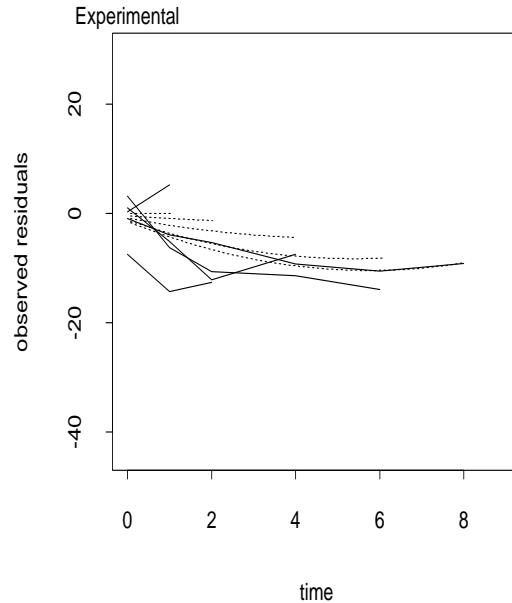
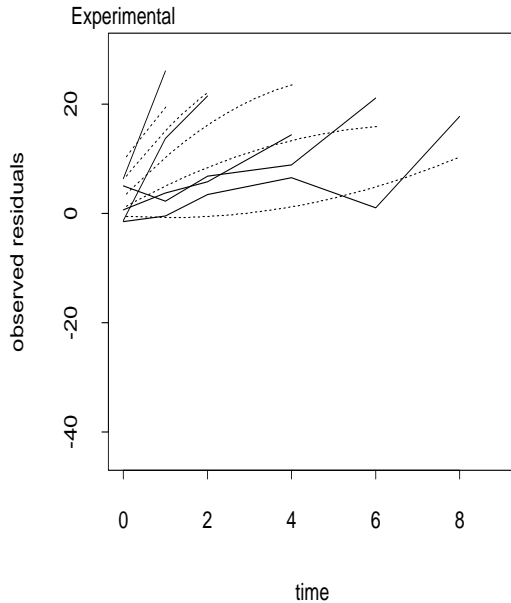

Mean observed (solid line) and expected (broken line) residual profiles for schizophrenia experimental data. Left: informative dropout groups. Right: non-informative dropout groups

Comments

- Other approaches possible, eg
 - ★ Nonparametric, especially for treatment effects
 - ★ Multivariate, treat $\log(T)$ as response
- Hazard based models preferred?
- Joint modelling
 - ★ as a survival problem ✓
 - ★ for longitudinal data ?

Selected references

www.maths.lancs.ac.uk/~henderr1/hdd.dir/jtmod.pdf